

Model	Unit	CBD2
Capacity Q	Kg	2000
Operate mothed	mm	Stand
Length of forks (A)	mm	1220
Centre of load(B)	mm	600
Overall length(include peldal)	mm	2400
Overall height(D)	mm	830
Overall width(E)	mm	750
Width of fork (F)	mm	160
Overall width of fork(G)	mm	660
Lower height(h)	mm	85
Lifting height (H)	mm	205
Min.Turning Radius(R)	mm	2220
Lifting speed(Load/Unload)	mm/s	25/30
Speed (Load/Unload)		4/6
Descending speed	Km/h	Controllable
Creeping degree(Load/Unload)	%	5/8
Brake way		Electromagnetic
Drive wheel	mm	Φ 250*80
Bearing wheel	mm	Φ 80*68
Balance wheel	mm	Φ 125*50
Lifting motor	kw	0.8
Drive wheel	kw	1.2
Battery	V/Ah	24/210
Net.Weight	kg	600

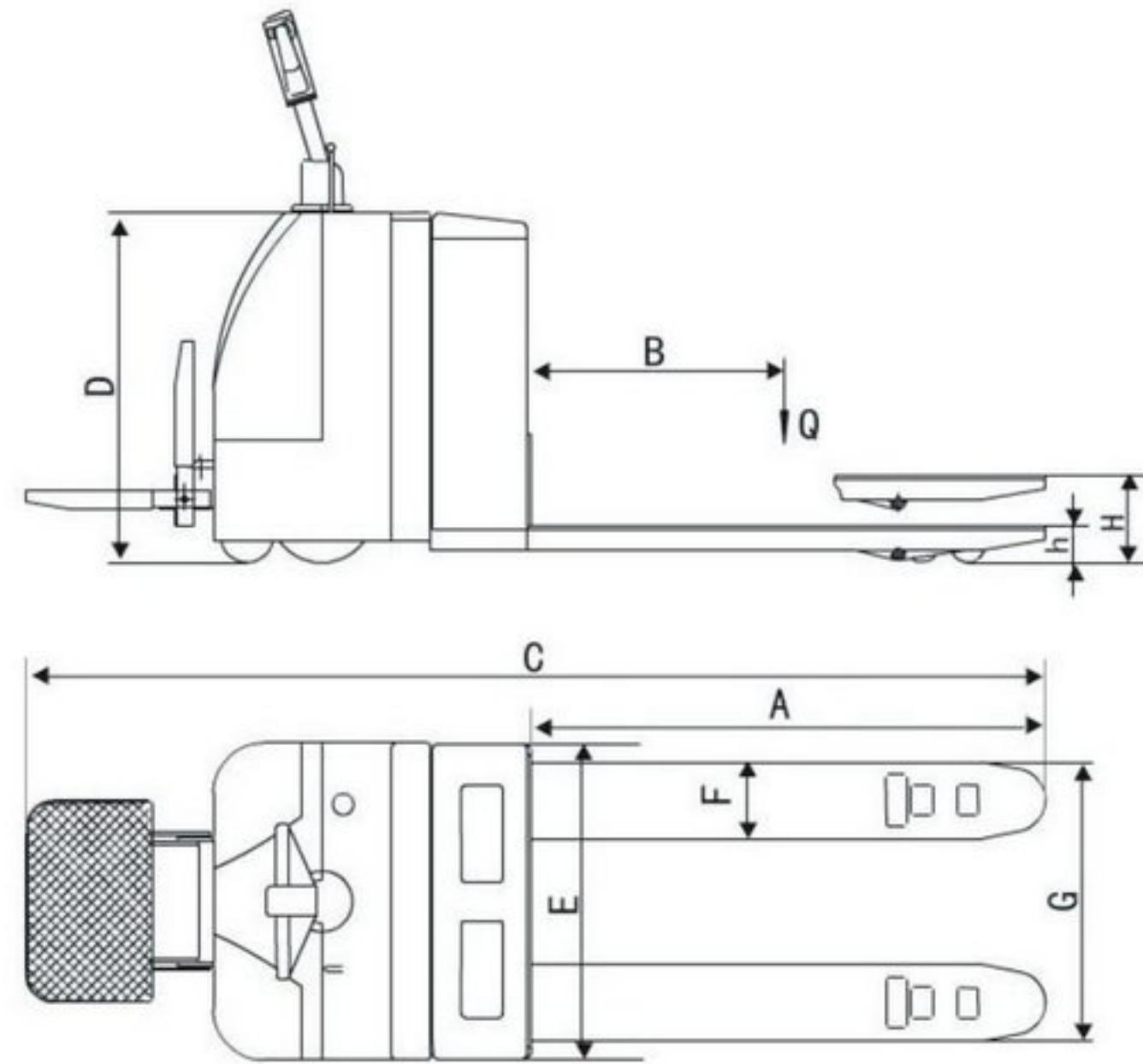

CBD



Features:

- Body part adopts welded steel structure, durable.
- Control handle adopts ergonomic design acceleration, much more humanization.
- Adopting PU wheels , which are wear-resisting, pressure-proof and mute.
- Installing intelligent battery charger outside, reliable and convenient.
- Top quality and capacity battery, which can work for a long time, reliable.

Main drive wheel
made in **Italy**

America
Curtis electric controll.

Pump station from
Taiwan