

DIMENSIONS

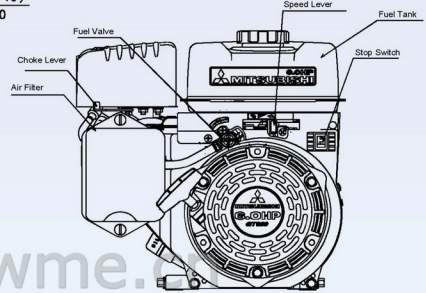

PTO SHAFT TYPE

GT600	JIS (with JIS Mount Flange)	SAE (with SAE Mount Flange)
KEYWAY (General)		
PUMP		
TAPER (Generator)		

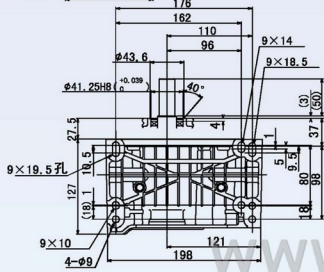
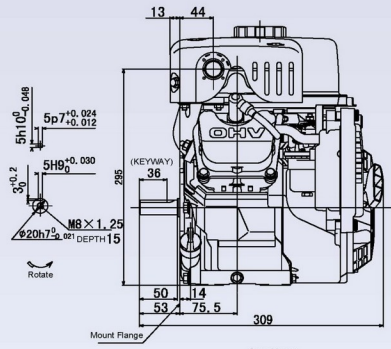
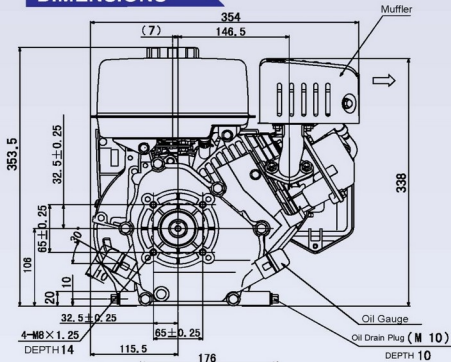

www.wme.cn