



Track Excavator

# 210E

- Operating Weight (Ton) 21
- Standard Bucket Capacity (m<sup>3</sup>) 0.9
- Engine Power 126kW (172hp) @ 2,100rpm



**Whatever task you throw at the 210E , it will accomplish it and some more**

An able contender for the all-rounder division, the 210E packs almost every excavation needs into one convenient machine. With the latest technological advancements that make it agile, strong and efficient, the 210E will take on just about any task you set on it and perform far beyond your expectations in the fields of general constructions such as pipe laying and road building.



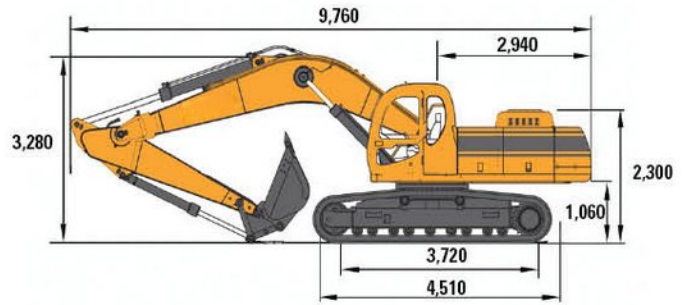
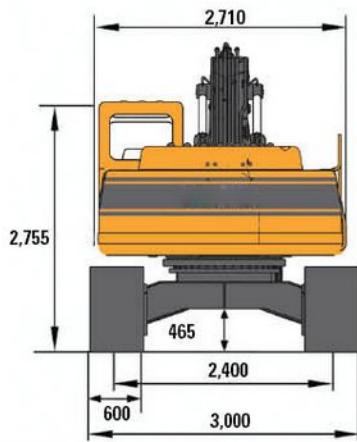

## SPECIFICATIONS

Operating Weight (Tons)	21	Hydraulic Component	Well-known Brands
Standard Bucket Capacity (m <sup>3</sup> )	0.9	Max Hydraulic Flow (L/min)	2 X 235
Diesel Engine	Cummins	Max Working Pressure (MPa)	30
Engine Model	6BTA5.9-C	Travel Speed (km/h)	3-5
Engine Power (kW)	126kW (172hp) @ 2,100rpm	Grade Climbing Capacity (%)	65
Arm/Stick Digging Force (kN)	102.5	Slewing Speed (r/min)	13
Bucket Digging Force (kN)	120.5	Ground Pressure (kPa)	42

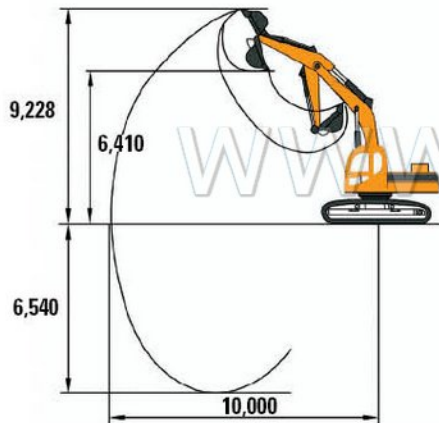

## APPLICATIONS



## OPERATING SCOPE

Arm/Stick Length (mm)	2,920
Maximum Digging Height (mm)	9,228
Maximum Dumping Height (mm)	6,410
Maximum Digging Depth (mm)	6,540
Maximum Reach (mm)	10,000

Note: Specifications are subject to change by the manufacturer without prior notice.

