

Optional Equipment	Note
Heating type body	Engine exhaust gas heating structure
Low-temperature start-up system	Suitable for extremely low temperature regions
Enlarged body	Suitable for lighter weight material
Heavy-duty body	Suitable for heavier weight material
Wear-resistant truck body liners	Suitable for very abrasive material
Automatic fire extinguishing system	Automatic fire extinguishing for engine
Automatic lubrication system	For regular grease filling in a specified amount
Automatic weighing system	Real-time loaded weight monitoring
Tire pressure monitoring system	Realtime tire pressure and temperature monitoring

OFF-HIGHWAY MINING TRUCK SRT95C



Nominal Payload
95tonnes/105tons

Gross Vehicle Weight (GVW) up to
160tonnes/176tons

Gross Power
783kW

Technical Data

Overall Parameters	Unit	Value
Overall dimensions: L × W × H	mm/in	10,100×6,095×4,890(11,080) /298×240×193 (436)
Wheelbase	mm/in	4,570/180
Front track width	mm/in	4,215/166
Rear track width	mm/in	3,420/135
Ground clearance	mm/in	745/29
Max. steering angle of front wheels	°	40
Min. steering radius	mm/in	12,000/472
Gross power	kW/hp	783/1,050
Max. speed	km/h/ mph	48/30
Max. Gradeability	%	30
Struck SAE	m ³ /yd ³	42/55
Heaped SAE 2:1	m ³ /yd ³	60/79

Weight Distribution

Axle Capacity	Front Axle	Rear Axle
Unloaded	48%	52%
Loaded	32%	68%

Overall Dimensions

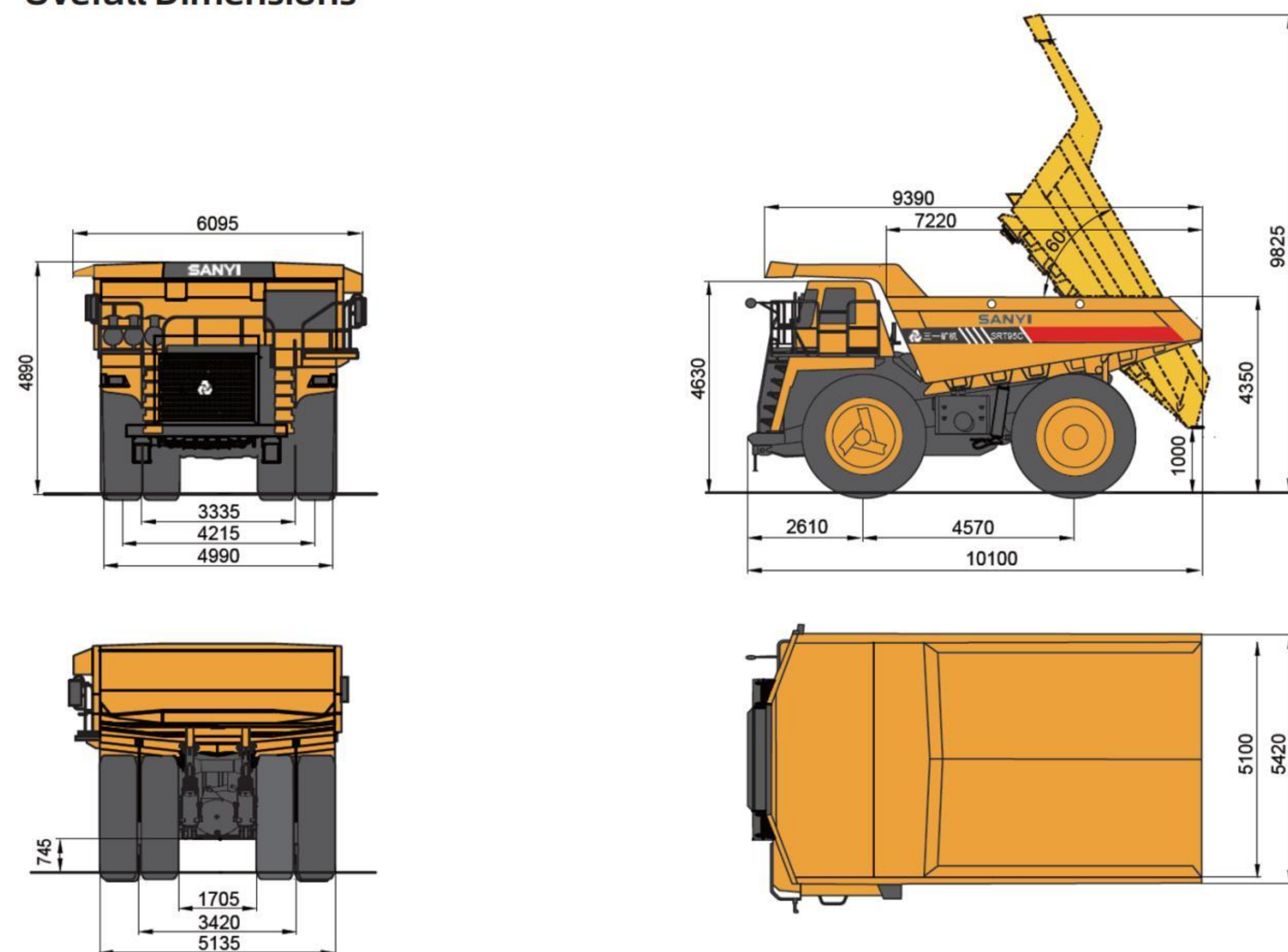

Dimension Unit:mm

* Dimensions may vary due to different configurations. The specific parameters are subject to actual conditions.

Fluid Capacities

Fluid Capacities	L
Engine crankcase and filter (engine oil)	134
Transmission and filter (automatic transmission exclusive oil)	100
Cooling system (antifreeze)	300
Fuel tank (diesel)	1,130
Steering hydraulic oil tank (hydraulic oil)	62
Steering hydraulic system · total (hydraulic oil)	170
Lift hydraulic oil tank (hydraulic oil)	280
Lift hydraulic and brake cooling system	480
Wheel rim reducer · total (gear oil)	57
Differential (gear oil)	61
Front suspension · each (hydraulic oil)	30×2
Rear suspension · each (hydraulic oil)	21×2
Power take-off	4

Weight Parameters

Item	kg	lb
Chassis, with hoists	52,000	114,000
Body, standard	13,000	29,000
Net weight	65,000	143,000
Rated payload	95,000	209,000
Max. gross weight	160,000	352,000

* The maximum gross vehicle weight (GVW) includes optional equipment, all accessories, fully filled fuel tank, loadings, etc; Overload will seriously deteriorate the lives of the components and the truck!

Main Configurations

Engine

- Model: Cummins QST30-C1050;
- Type: 4 cycle turbocharged charge air cooled;
- Gross power @2,100rpm: 783kW/1,050hp;
- Net power @2,100rpm: 728kW/976hp;
- Power ratings based on SAE J1995 June 90. Engine emission meets Tier 2 USA EPA/CARB MOH 40 CFR 89 and proposed EU non-road mobile machinery directive;
- Max. torque @1,300rpm: 4,629N.m(3,415lb·ft);
- Number of cylinders/configuration: 12,V type;
- Bore stroke: Φ 140mm x 165 mm/Φ 5.51" x 6.49";
- Displacement: 30.5L.

Transmission

- Allison H8610AR electronic automatic control transmission with flexible shift characteristics. CEC2 commercial electronic control system. Integrated hydraulic torque converter and hydraulic retarder. Six speeds forward, one reverse. Automatic lockup in all speed ranges. Transmission is provided with hydraulic retarder and hoist restrict shift protect function.

	Forward						Reverse
	1st	2nd	3rd	4th	5th	6th	r1
Ratio	4.24	2.32	1.69	1.31	1	0.73	5.75
Km/h	8	14.7	20.1	26	34	48	6
Mile/h	5	9.2	12.5	16.2	21.2	30	3.8

Brakes

- Service Brake: All hydraulic brake system control. Transmission PTO mounted pressure compensating piston pump provides hydraulic pressure for brakes and steering. Independent circuits front and rear.Each circuit incorporates an accumulator which stores energy to provide instant braking response;
- Front: Dry disc brake; Disc diameter 965 mm (38in);
- Pad area, total 1,960 cm² (304in²);
- Rear: Oil-cooled, disc brake, completely sealed from dirt and water;
- Braking surface, total 91,000 cm² (14,105in²);
- Parking Brake - Rear brakes applied by spring loaded opposing piston on disc pack, hydraulically released;
- Retarding Brake - Two levers separately control the rear disc brakes and hydraulic retarder in transmission;
- Emergency Brake - Through solenoid valve to provide service brakes and parking brake.

Steering

- Independent hydraulic steering with closed-center steering valve, pressure compensating piston pump and accumulator;
- Accumulator provides uniform steering regardless of engine speed. In the event of loss of engine power, it provides emergency power to system for steering. A low pressure indicator light warns of system pressure below 115bar (1,660 lbf/in²);
- Minimum turning diameter: 24,000mm.

Tires

- Tyre Model: 27.00R49 E-4;
- Under certain working conditions, TKPH(ton-Km/h) capabilities of standard tyres could be exceeded. Consult tyre manufacturers for optimum tyre selection.

Frame

- Box structure with variable-section provides resistance to bending and torsion;
- Mild steel used throughout bumper, front and rear longitudinal beams provides flexibility and resistance to impact loads. Low alloy cast-steel components are used in the high-stress areas for a higher strength and greater life frame.

Drive Axle

- Heavy duty axle with full floating axle shafts, single reduction spiral bevel gear differential, and planetary reduction at each wheel. High strength cast steel welded construction;
- Ratios: Differential: 2.16: 1
Planetary: 13.75: 1
Total Reduction: 29.70: 1.

Suspension

- Front: Macpherson type independent suspension with variable rate, nitrogen/oil cylinder for effective absorption of road shocks;
- Rear: Variable rate nitrogen/oil cylinders with A-frame linkage and lateral stabilizer bar;
- Maximum strut stroke: Front: 345 mm (13.6 in);
Rear: 200 mm (6.9 in);
- Maximum rear axle oscillation: ±7°.

Hoist

- Independently hydraulic system.Two hoist cylinders are mounted on both sides of the frame rails to keep stable of body while raises the body;
- Body hydraulic pump flow rate @ 2,100 rpm engine:529L/min(139USgal/min);
- Liftings ≤ 19s, Lowering ≤ 18s.

Body

- The body is dual "V" structure which gives good load retention and a low centre of gravity. The bottom,side and front plates are constructed from high tensile strength abrasion-resistant steel; Thickness:Floor 20 mm,Side 10 mm,Front 10 mm;
- Struck (SAE std): 42m³ (55yd³);
- Heaped 2:1 (SAE std): 60 m³ (79 yd³).

Cab

- FOPS/ROPS certified. Equipped with integral four-pillar tipping protection design, adjustable cushioned seat, luxury upholstery, and tiltable and telescopic steering wheel to provide a comfortable operating space;
- The cab conforms to the requirements of ISO 3471. The cab provides a sound exposure Leq (equivalent sound level) of less than 78 dB(A) when tested with doors and windows closed.