



CCC 强制性产品认证



ISO9001 质量管理体系认证



ISO14001 环境管理体系认证



中国职业安全健康管理体系认证

安全 · 环保 · 时尚 · 领先



★新一代
★K系列
★领先型

SQ10SK3Q
随车起重机

TRUCK - MOUNTED CRANE

Truck Mounted Crane SQ10SK3Q

www.wme.cn/TruckMountedCrane/

TRUCK – MOUNTED CRANE

SQ10SK3Q 随车起重机

起重能力曲线图 CURVE GRAPH OF LIFTING CAPACITY

单位: mm

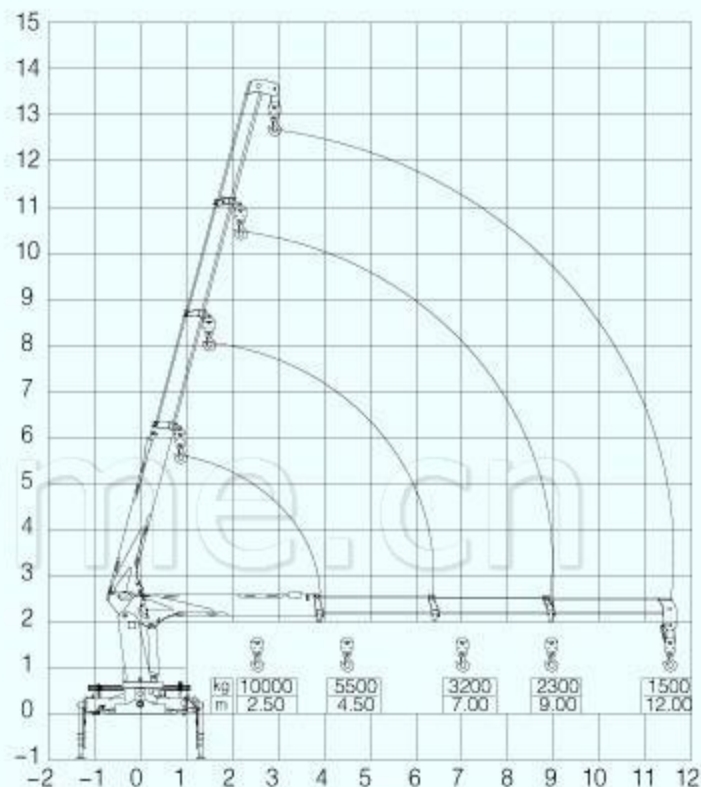
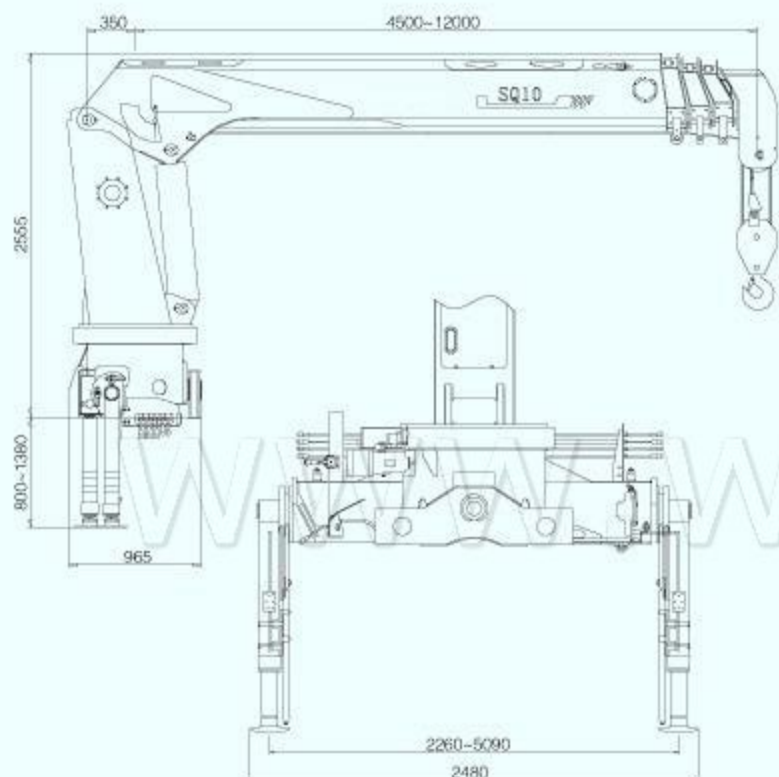

起重机主要技术参数 MAIN SPECIFICATION

最大起升质量	Max Lifting Capacity	10000	kg
最大起重力矩	Max Lifting Moment	25	T.M
推荐功率	Recommend Power Needed At Recommend Oil Flow	28	kw
液压系统最大流量	Max Oil Flow Of Hydraulic System	63	L/min
液压系统额定压力	Rated Pressure Of Hydraulic System	26	MPa
油箱容积	Oil Tank Capacity	180	L
回转角度	Rotation Angle	全回转	All Rotation
起重机自重	Crane Weight	3800	kg
此重量为参考值, 具体以公告为准			
安装空间	Installation Space	1150	mm

主要特点 MAIN FEATURE

- 1、绳排式同步伸缩吊臂, 作业效率更高, 起重能力更强。
 - 2、行星式起升绞车, 有效降低系统温度, 作业速度更快, 可靠性更高。
 - 3、分体式操作机构, 更加安全、便捷。
- 1、The synchronous telescoping boom of steel cable type makes a higher efficiency and lifting capacity.
 - 2、The planet lifting winch that reduces the temperatures of the hydraulic system efficiently and gives a faster lifting speed and higher reliability.
 - 3、The separation controlling system is more safety and convenient.