



中国强制认证



ISO9001质量管理体系认证



ISO14001环境管理体系认证



中国职业安全健康管理体系认证

安全 · 环保 · 时尚 · 领先



★新一代  
★K系列  
★领先型

# SQ6.3SK2Q/K3Q 随车起重机 TRUCK - MOUNTED CRANE

# TRUCK - MOUNTED CRANE

## SQ6.3SK2Q/K3Q随车起重机

SQ6.3SK2Q起重能力曲线图 CURVE GRAPH OF LIFTING CAPACITY

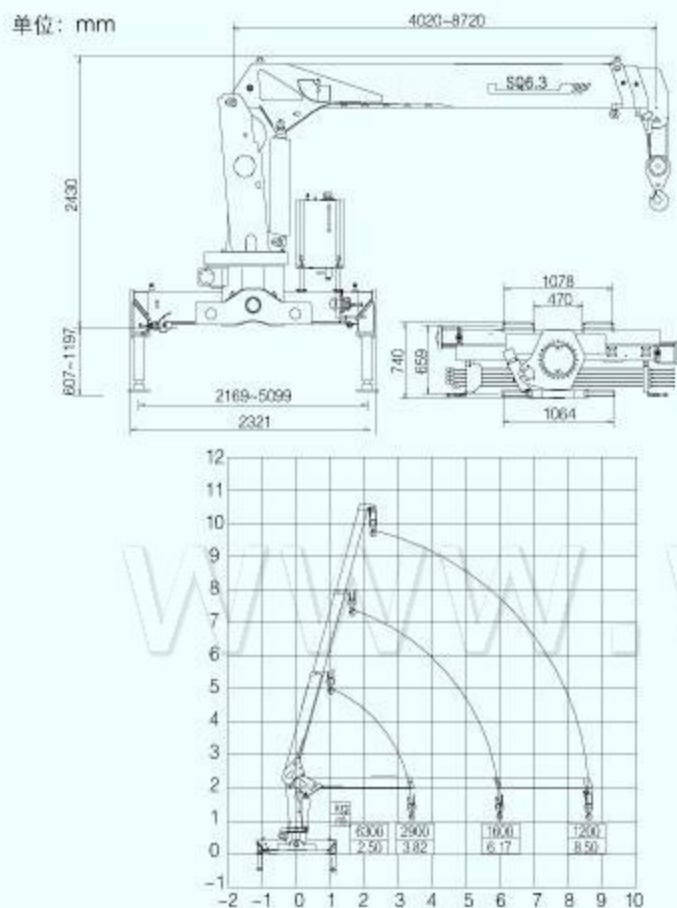

SQ6.3SK3Q起重能力曲线图 CURVE GRAPH OF LIFTING CAPACITY

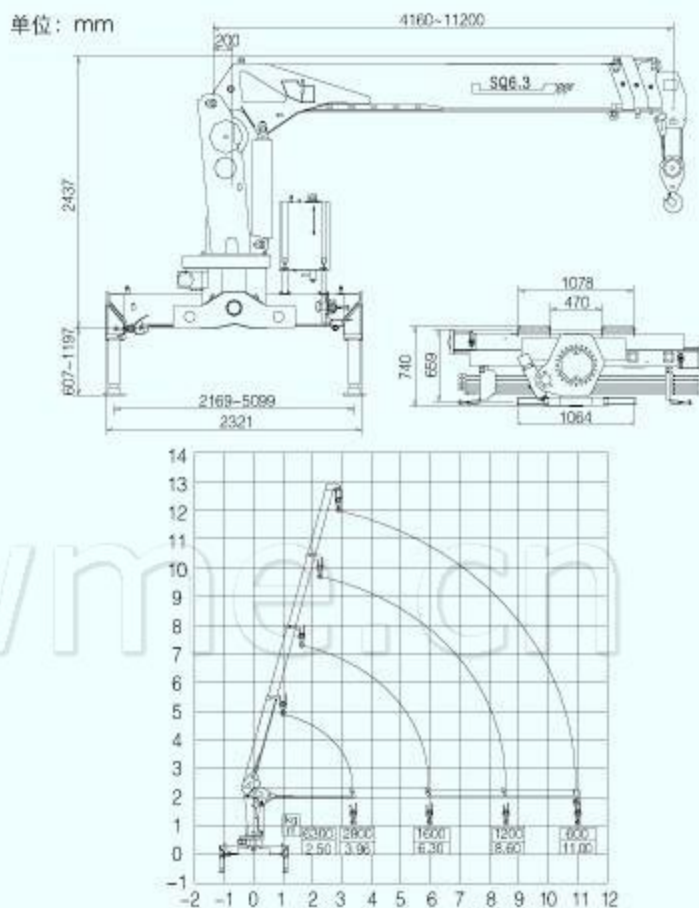

SQ6.3SK2Q起重机主要技术参数 MAIN SPECIFICATION

最大起升质量	Max Lifting Capacity	6300	kg
最大起重力矩	Max Lifting Moment	15.7	T.M
推荐功率	Recommend Power Needed At Recommend Oil Flow	20	kw
液压系统最大流量	Max Oil Flow Of Hydraulic System	40	L/min
液压系统额定压力	Rated Pressure Of Hydraulic System	20	MPa
油箱容积	Oil Tank Capacity	90	L
回转角度	Rotation Angle	全回转	All Rotation
起重机自重	Crane Weight	2117	kg
此重量为参考值, 具体以公告为准			
安装空间	Installation Space	900	mm

SQ6.3SK3Q起重机主要技术参数 MAIN SPECIFICATION

最大起升质量	Max Lifting Capacity	6300	kg
最大起重力矩	Max Lifting Moment	15.7	T.M
推荐功率	Recommend Power Needed At Recommend Oil Flow	20	kw
液压系统最大流量	Max Oil Flow Of Hydraulic System	40	L/min
液压系统额定压力	Rated Pressure Of Hydraulic System	20	MPa
油箱容积	Oil Tank Capacity	90	L
回转角度	Rotation Angle	全回转	All Rotation
起重机自重	Crane Weight	2270	kg
此重量为参考值, 具体以公告为准			
安装空间	Installation Space	900	mm

### 主要特点 MAIN FEATURE

1. 内置拉索式同步伸缩吊臂, 作业效率更高, 起重能力更强。
2. 安装空间进一步缩小, 整车更加紧凑。
3. 总体设计更具人性化, 外观更时尚。

1. The synchronous telescoping boom of inner put steel cable type makes a higher efficiency and lifting capacity
2. Much smaller installation spaces to make the vehicles more compact
3. Much more human oriented design and better looking