



中国强制认证
"CCC"强制性产品认证



ISO9001质量管理体系认证



ISO14001环境管理体系认证



中国职业安全健康管理体系认证



安全 · 环保 · 时尚 · 领先

- ★ 新一代
- ★ K系列
- ★ 领先型

SQ8ZK3Q

随车起重机

TRUCK - MOUNTED CRANE

TRUCK - MOUNTED CRANE

SQ8ZK3Q 随车起重机

起重能力曲线图 CURVE GRAPH OF LIFTING CAPACITY

单位: mm

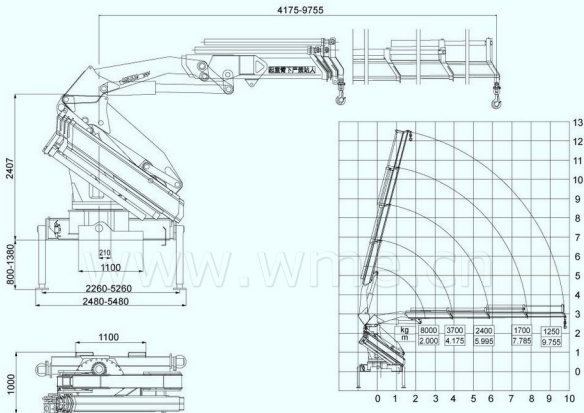

起重机主要技术参数 MAIN SPECIFICATION

最大起升质量	Max Lifting Capacity	8000	kg
最大起重力矩	Max Lifting Moment	16	T.M
推荐功率	Recommend Power Needed At Recommend Oil Flow	28	kw
液压系统最大流量	Max Oil Flow Of Hydraulic System	40	L/min
液压系统额定压力	Rated Pressure Of Hydraulic System	28	MPa
油箱容积	Oil Tank Capacity	140	L
回转角度	Rotation Angle	全回转	All Rotation
起重机自重	Crane Weight	2970	kg
此重量为参考值, 具体以公告为准			
安装空间	Installation Space	1150	mm

主要特点 MAIN FEATURE

- 1、六边形吊臂具有更高的强度。
- 2、高性能大扭矩回转减速装置, 保证各种恶劣工况下的安全操作。

1. Hexagon boom with high rigidity.
2. Equipment with higher quality and bigger torque guarantee the controlling security in all kinds of adverse situation.