



安全 · 环保 · 可靠 · 领先

★新一代
★K系列
★领先型

SQZ800K6Q
随车起重机
TRUCK - MOUNTED CRANE

TRUCK - MOUNTED CRANE

SQZ800K6Q 随车起重机

单位: mm

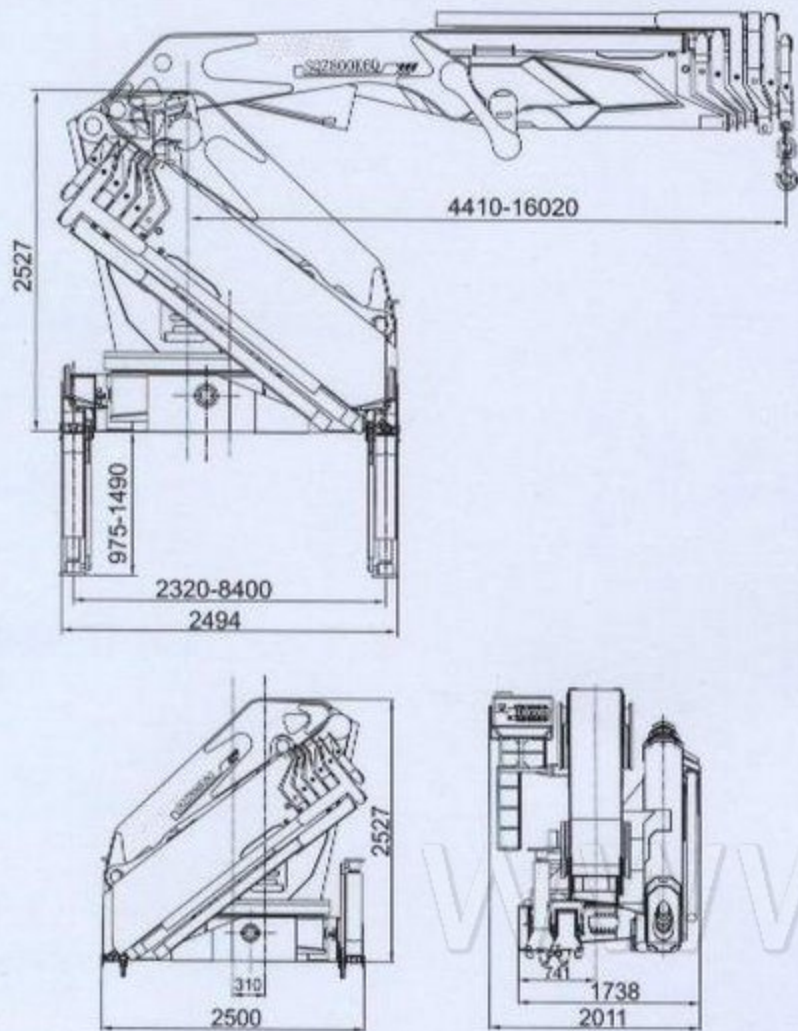

起重机主要参数 MAIN SPECIFICATION

最大起升质量	Max Lifting Capacity	40000	kg
最大起重力矩	Max Lifting Moment	80	T.M
推荐功率	Recommend Power	60	kw
液压系统最大流量	Max Oil Flow of Hydraulic System	120	L/min
液压系统额定压力	Max Pressure of Hydraulic System	33	MPa
油箱容积	Oil Tank Capacity	300	L
起重机自重	Crane Weight	8560	kg
安装空间	Installation Space	2000	mm
回转角度	Rotation Angle	360° 全回转 All Rotation °	

主要特点 MAIN FEATURE

- 1、超高强板的应用使得整机重量更轻，起重性能更强；
- 2、对称式八边形吊臂结构起重性能更强、刚性更好；
- 3、流量再生平衡阀提高吊臂的伸出速度；
- 4、自动过载保护力矩限制(OLP)系统的应用使得整机安全性能更高；
- 5、大跨距双腔伸缩支腿提高起重机稳定性；
- 6、液压支腿自动翻转机构，提高整机的适应性能。

- 1、 Superhigh reinforce board makes crane lightweight and have higher lifting capacity.
- 2、 Symmetry of octagon boom with higher lifting capacity and rigidity.
- 3、 flow regeneration balance valve can improve boom extending speed .
- 4、 the available of overload protection system makes higher safety performance.
- 5、 Big span stabilizer legs can improve crane's stability.
- 6、 Automatic reversal mechanism for hydraulic leg can improves the adaptable ability for truck-mounted crane.

